

Locking assembly MAV 4061 L

rev. 0

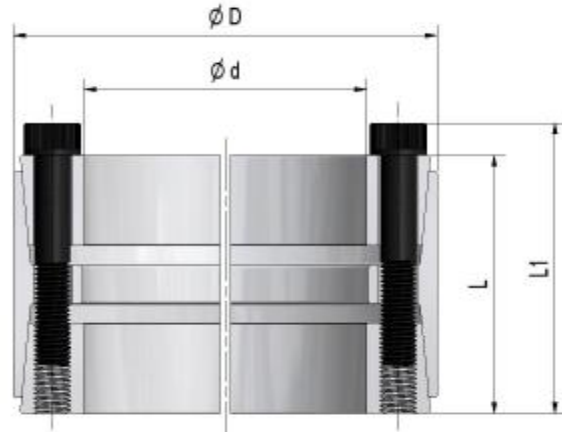

High torque capacity
 Self-locking & self-centering
 Axial fixation of hub during tightening: no
 Max tolerances: shaft h8; hub bore H8
 Shaft / hub bore max surface finish: $R_a \leq 3.2 \mu\text{m}$

Example of order: MAV4061L - 50 x 80 (d x D)

M_a : screw tightening torque
 M_t : transmissible torque ($F_{ax}=0$)
 F_{ax} : transmissible axial load ($M_t=0$)
 p_s : shaft pressure
 p_h : hub pressure

DIMENSIONS					SCREWS UNI 5931 - 12.9		PERFORMANCES				WEIGHT
d	x	D	L	L ₁	size	M _a	M _t	F _{ax}	p _s	p _h	kg
mm		mm	mm	mm		Nm	Nm	kN	N/mm ²	N/mm ²	
50	x	80	78	86	M 8	41	4.600	183	173	108	1,5
55	x	85	78	86	M 8	41	5.600	205	177	114	1,6
60	x	90	78	86	M 8	41	6.800	228	180	120	1,7
65	x	95	78	86	M 8	41	7.400	228	166	114	1,8
70	x	110	102	112	M 10	83	12.300	353	171	109	3,7
75	x	115	102	112	M 10	83	13.200	353	160	104	3,9
80	x	120	102	112	M 10	83	15.500	388	165	110	4,1
85	x	125	102	112	M 10	83	16.500	388	155	106	4,3
90	x	130	102	112	M 10	83	19.100	423	160	111	4,5
95	x	135	102	112	M 10	83	20.100	423	152	107	5,8
100	x	145	122	134	M 12	145	29.000	580	162	112	6,9
110	x	155	122	134	M 12	145	34.800	632	161	114	7,3
120	x	165	122	134	M 12	145	44.300	738	172	125	8,1

Information subject to change without prior notification, © MAV S.p.A.